

Datasheet

F1 Smart Module

March 2024 V1.1



Introduction

The F1 Smart Module (order part number SGW3501) is a compact OEM module equipped with BLE, Wi-Fi, LoRa(WAN), and LTE CAT-M1/NB1/NB2 to support various connectivity needs. Running on a MicroPython-programmable microcontroller with a no-barrier entry into the SG Wireless Ctrl. Cloud Platform, the module enables truly limitless IoT application development with multi-network creation flexibility and rapid scaling capacity.

The F1 Smart Module has three variants with various connectivity options.

- Multi-connectivity:
 - Wi-Fi 802.11b/g/n (2.4GHz)
 - Bluetooth BLE 5.0
 - Cellular LTE-CAT M1/NB1/NB2
 - Semtech LoRa(WAN) 868MHz/915MHz
- Powerful Espressif ESP32 S3 CPU
- MicroPython programmable with 27 IOs on module pads
- SMT-friendly semi-hole pins at module edges
- Operating temperature: 0°C to 85°C
- Compact size-to-functionality ratio: 42.6mm x 17.6mm x 3.6mm

Order Part Number	Description
SGW3501	F1 Smart Module: BLE, Wi-Fi, LoRa, LTE
SGW3401	F1/C Cellular Module: BLE, Wi-Fi and LTE
SGW3201	F1/L LoRa Module: BLE, WiFi and LoRa

Contents

1. General Features	3
a. Feature Specifications	3
b. Block Diagram	3
2. Electrical Specifications	4
a. Absolute Rating and Operating Conditions	4
b. Wi-Fi	4
c. Bluetooth	5
d. LTE	5
e. LoRa	6
3. Module Interface	7
a. Power Management	7
b. Memory Allocation	7
4. Mechanical Data	7
a. Mechanical Specification	7
b. Module Pin-out	8
c. Recommended PCB Landing Pattern	10
d. Recommended Basic Circuit	11
e. Recommended Soldering Profile	11
5. MicroPython Application Development on F1	12
a. Device Programming via UART	12
b. Module-supported libraries	12
c. MicroPython Capability – REPL (Read-Eval-Print Loop)	12
6. Product Packaging	13
7. Revision History	14

1. General Features

a. Feature Specifications

CPU
<ul style="list-style-type: none"> • Xtensa® dual-core 32-bit LX7 microprocessor, up to 240Mhz • On-chip 384KB ROM and 512KB SRAM, on-board 8MB PSRAM and 16MB Flash • Deep Sleep Mode: 10µA
Wi-Fi/BLE
<ul style="list-style-type: none"> • Espressif ESP32-S3 on-chip RF frontend • Wi-Fi: IEEE 802.11b/g/n (2.4GHz band); Data Rate: 1M up to 54Mbps (MCS7); Max Tx Power: 20dBm • BLE: Bluetooth LE 5.0, Bluetooth mesh; Data Rate: 125kbps to 2Mbps; Max Tx Power: 20dBm
LTE
<ul style="list-style-type: none"> • Sequans Monarch2 GM02S for CAT-M1, CAT-NB1 and CAT-NB2 support • LTE CAT-M1/NB1/NB2 transmit power up to +23dBm • PTCRB and GCF 1.3 3GPP release 13 compliant; Operator Approval: Verizon, AT&T, T-Mobile, Vodafone, Orange
LoRa
<ul style="list-style-type: none"> • Semtech SX1262 RF transceiver, 868/915MHz LPWAN Module • TX Power: Up to +22dBm; Sensitivity: -127dBm • LoRaWAN stack – Class A and Class C Device

b. Block Diagram

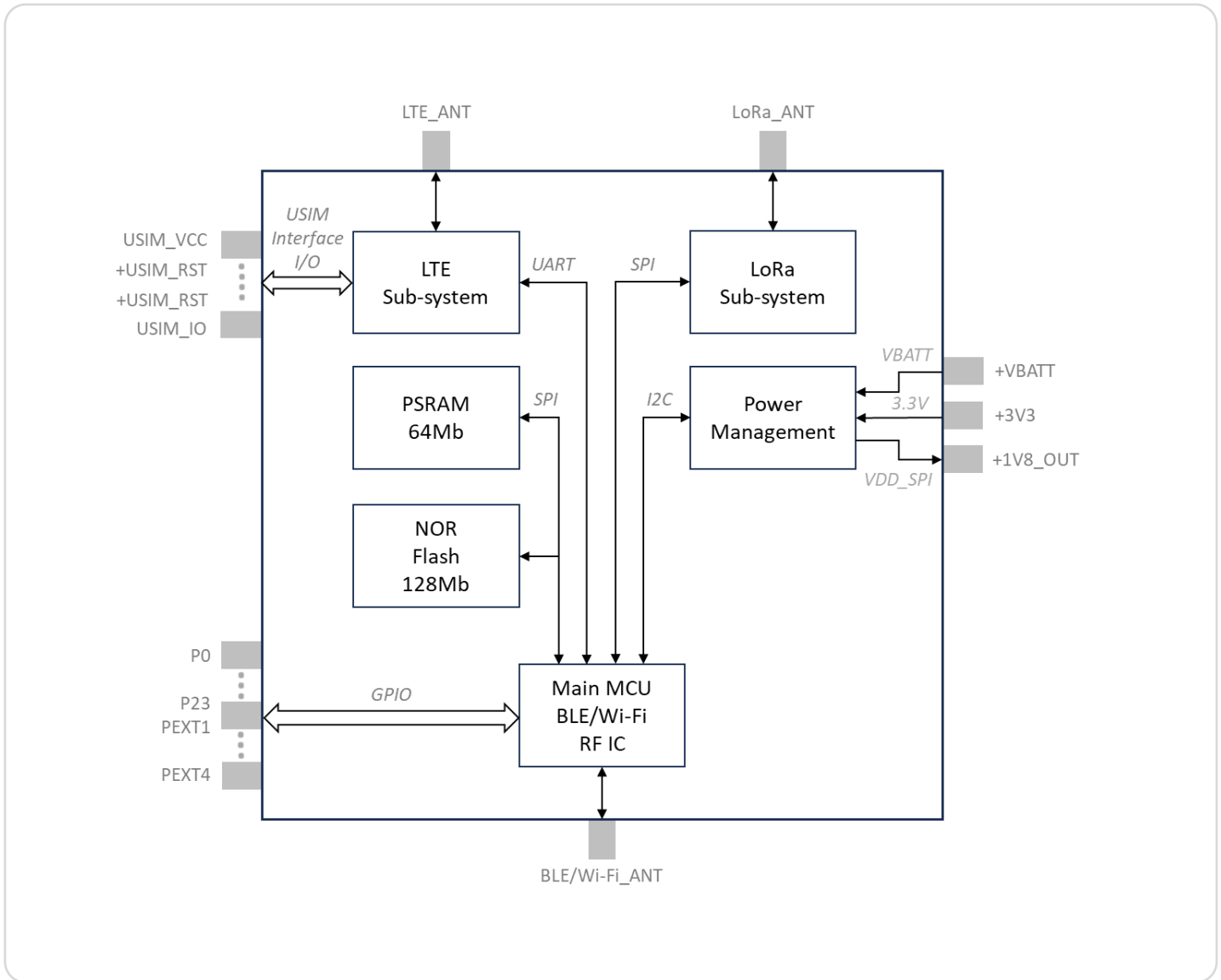

Figure 1: F1 Smart Module Block Diagram

2. Electrical Specifications

a. Absolute Rating and Operating Conditions

Table 1: Absolute Rating and Operating Conditions Specifications

Symbol	Parameter	Min	Typ	Max	Unit
Absolute Rating					
+VBATT	Supply voltage to Sequans GM02S LTE module		5.0	5.8	V
+3V3	Supply voltage to Espressif ESP32-S3 and module main circuit	3.0	3.3	3.6	V
+1V8_OUT*	SPI supply voltage (output) of SPI flash and PSRAM for decoupling capacitor connection		1.8	2.3	V
T(OPR)	Operating temperature	-40		85	°C
Operating Conditions					
+VBATT	Supply voltage to Sequans GM02S LTE module	2.5	5.0	5.5	V
+3V3	Supply voltage to Espressif ESP32-S3 and module main circuit	3.2	3.3	3.4	V
+1V8_OUT*	SPI supply voltage (output) of SPI flash and PSRAM for decoupling capacitor connection	1.7	1.8	1.9	V
CPU IO (3.3V power domain, VDD=3.3V)					
VIH	Input high voltage for GPIOs	0.75 x VDD		VDD + 0.3	V
VIL	Input low voltage for GPIOs	-0.3		0.25 x VDD	V
VOH	Input high voltage for GPIOs	0.8 x VDD			V
VOL	Input low voltage for GPIOs			0.1 x VDD	V
Radio IO (1.8V power domain)					
VIH	Input high voltage for GPIOs	1.26		1.8	V
VIL	Input low voltage for GPIOs	0		0.54	V
VOH	Input high voltage for GPIOs	1.44		1.8	V
VOL	Input low voltage for GPIOs	0		0.36	V

* The +1V8_OUT pin is to connect an external capacitor to the module internal SPI flash and PSRAM for a more robust VDD_SPI supply. This pin should not be connected to any external circuits that may draw more than 20mA. Voltage of this pin will vary in module light sleep mode and approach zero in module deep sleep mode.

b. Wi-Fi

Standard: 802.11b/g/n (2.4GHz ONLY) – 1T1R

Table 2: Wi-Fi Specifications

Parameter	Description	Min	Typ	Max	Unit
General					
Freq. (EU)	Operating frequency (EU)	2.402		2.482	GHz
Ch. (EU)	Channel (EU)	1		13	
Freq. (US)	Operating frequency (US)	2.402		2.472	GHz
Ch. (US)	Channel (US)	1		11	
Power max. (EU/US)	Maximum power (EU/US)			20	dBm
Tx					
Tx Power @B – 1Mbps	Tx power at B mode with data rate 1Mbps		18	20	dBm
EVM (Peak) @B – 1Mbps	EVM(Peak) at B mode with data rate 1Mbps			8	%
Freq. Err. @B – 1Mbps	Frequency error at B mode with data rate 1Mbps	-40	0	40	kHz
Tx Power @G – 54Mbps	Tx power at G mode with data rate 54Mbps		16	20	dBm
EVM (RMS) @G – 54Mbps	EVM(RMS) at G mode with data rate 54Mbps			-25	dB
Freq. Err. @G – 54Mbps	Frequency error at G mode with data rate 54Mbps	-40	0	40	kHz
Tx Power @N20 – MCS7	Tx power at N mode with data rate MCS7 and 20MHz bandwidth		15	20	dBm
EVM (RMS) @N20 – MCS7	EVM rms at N mode with data rate MCS7 and 20MHz bandwidth			-27	dB
Freq. Err. @N20 – MCS7	Frequency error @ N mode with data rate MCS7 and 20MHz bandwidth	-40	0	40	kHz
Tx Power @B – 1Mbps	Tx power at B mode with data rate 1Mbps		18	20	dBm
Rx					
Rx Sens. @B – 1Mbps	Tx power at B mode with data rate 1Mbps		-92.0	-82.0	dBm
Rx Sens. @G – 54Mbps	Tx power at G mode with data rate 54Mbps		-76.5	-66.0	dBm
Rx Sens. @N20 – MCS7	Tx power at N mode with data rate MCS7 and 20MHz bandwidth		-71.4	-64.0	dBm

c. Bluetooth

Standard: BLE 5.0 – 1T1R

Table 3: Bluetooth Specifications

Parameter	Description	Min	Typ	Max	Unit
General					
Freq.	Operating frequency	2.4000		2.4835	GHz
Ch.	Channel	0		39	
Power max.	Maximum power			20	dBm
Tx					
Tx Power @Ch.37 – 1 Mbps	Tx power at channel 37 (freq.=2402MHz) with data rate 1Mbps		17	20	dBm
Freq. Err. @Ch.37 – 1Mbps	Frequency error at channel 37 (freq.=2402MHz) with data rate 1Mbps	-50	0	50	%
Tx Power @Ch.38 – 1Mbps	Tx power at channel 38 (freq.=2426MHz) with data rate 1Mbps		17	20	kHz
Freq. Err. @Ch.38 – 1Mbps	Frequency error at channel 38 (freq.=2426MHz) with data rate 1Mbps	-50	0	50	dBm
Tx Power @Ch.39 – 1Mbps	Tx power at channel 39 (freq.=2480MHz) with data rate 1Mbps		17	20	dBm
Freq. Err. @Ch.39 – 1Mbps	Frequency error at channel 39 (freq.=2480MHz) with data rate 1Mbps	-50	0	50	kHz
Rx					
Rx Sens. @Ch.38 – 2Mbps	Tx power at channel 38 (freq.=2426MHz) with data rate 2Mbps		-93.5		dBm
Rx Sens. @Ch.38 – 1Mbps	Tx power at channel 38 (freq.=2426MHz) with data rate 1Mbps		-97.5	-70.0	dBm
Rx Sens. @Ch.38 – 500kbps	Tx power at channel 38 (freq.=2426MHz) with data rate 500kbps		-100.0		dBm

d. LTE

Standard: CAT-M1, CAT-NB1, CAT-NB2

Table 4: LTE Frequency Bands (in MHz)

Band No.	Duplex Type	Uplink Frequency (MHz)	Uplink Bandwidth (MHz)	Downlink Frequency (MHz)	Downlink Bandwidth (MHz)	For LTE-M	For NB-IoT
1	FDD	1920 – 1980	60	2110 – 2170	60	✓	✓
2	FDD	1850 – 1910	60	1930 – 1990	60	✓	✓
3	FDD	1710 – 1785	75	1805 – 1880	75	✓	✓
4	FDD	1710 – 1755	45	2110 – 2155	45	✓	✓
5	FDD	824 – 849	25	869 – 894	25	✓	✓
8	FDD	880 – 915	35	925 – 960	35	✓	✓
12	FDD	699 – 716	17	729 – 746	17	✓	✓
13	FDD	777 – 787	10	746 – 756	10	✓	✓
14	FDD	788 – 798	10	758 – 768	10	✓	✓
17	FDD	704 – 716	12	734 – 746	12	*	✓
18	FDD	815 – 830	15	860 – 875	15	✓	✓
19	FDD	830 – 845	15	875 – 890	15	✓	✓
20	FDD	832 – 862	30	791 – 821	30	✓	✓
25	FDD	1850 – 1915	65	1930 – 1995	65	✓	✓
26	FDD	814 – 849	35	859 – 894	35	✓	✓
28	FDD	703 – 748	45	758 – 803	45	✓	✓
66	FDD	1710 – 1780	70	2110 – 2200	90	✓	✓
85	FDD	698 – 716	18	728 – 746	18	✓	✓

Table 5: LTE Specifications

Parameter	Description	Min	Typ	Max	Unit
General					
Power max.	Maximum power			23	dBm
Tx					
Tx power @Band 8 (900MHz GSM)	Tx power at Band 8 (900MHz GSM)		22	23	dBm
Tx power @Band 2 (1900MHz PCS)	Tx power at Band 2 (1900MHz PCS)		22	23	dBm
Rx					
Rx sens. @Band 8 (900MHz GSM)	Rx sensitivity at Band 8 (900MHz GSM)		-103	-100	dBm
Rx sens. @Band 2 (1900MHz PCS)	Rx sensitivity at Band 2 (1900MHz PCS)		-103	-100	dBm

e. LoRa

Mode: LoRa RAW mode and LoRa WAN mode

LoRaWAN Node Type: Class Type A, Class Type C

Frequency Band: EU868, US915

Table 6: LoRa Specifications

Parameter	Description	Min	Typ	Max	Unit
General					
Freq. (EU)	Frequency band (EU)	863		870	GHz
Freq. (US)	Frequency band (US)	902		928	GHz
Power max. (EU)	Maximum power (EU)			15	dBm
Power max. (US)	Maximum power (US)			22	dBm
Tx					
Tx power (Tx tone) @866.4MHZ [EU868 band]	Tx power (Tx tone) at 866.4MHz		14	15	dBm
Tx power (Tx tone) @918.2MHZ [US915 band]	Tx power (Tx tone) at 918.2MHz		21	22	%
Rx					
Rx Sens. @freq=866.4MHz, BW=500kHz, SF=12	Rx sensitivity at 866.4MHz, 500kHz bandwidth and SF=12		-127		dBm
Rx Sens. @freq=866.4MHz, BW=500kHz, SF=12	Rx sensitivity at 866.4MHz, 500kHz bandwidth and SF=12		-127		dBm

3. Module Interface

a. Power Management

Table 7: Power Consumption by Mode of Operation

Mode of Operation	Min	Typ	Max	Unit
Idle (no radio but MicroPython is running)		30		mA
Light sleep (wake up or restart is required for MicroPython to run)		800		μA
Deep sleep (wake up or restart is required for MicroPython to run)		10		μA

b. Memory Allocation

Module OS firmware, OTA and user space sizes:

- Module OS firmware: 2,560Kb
- OTA1 space: 2,560Kb
- OTA2 space: 2,560Kb
- User space: 8Mb

4. Mechanical Data

a. Mechanical Specification

All pins have a pin width of 0.7mm with the exception of pin VBATT (pin #A4) with pin width 1.0mm.

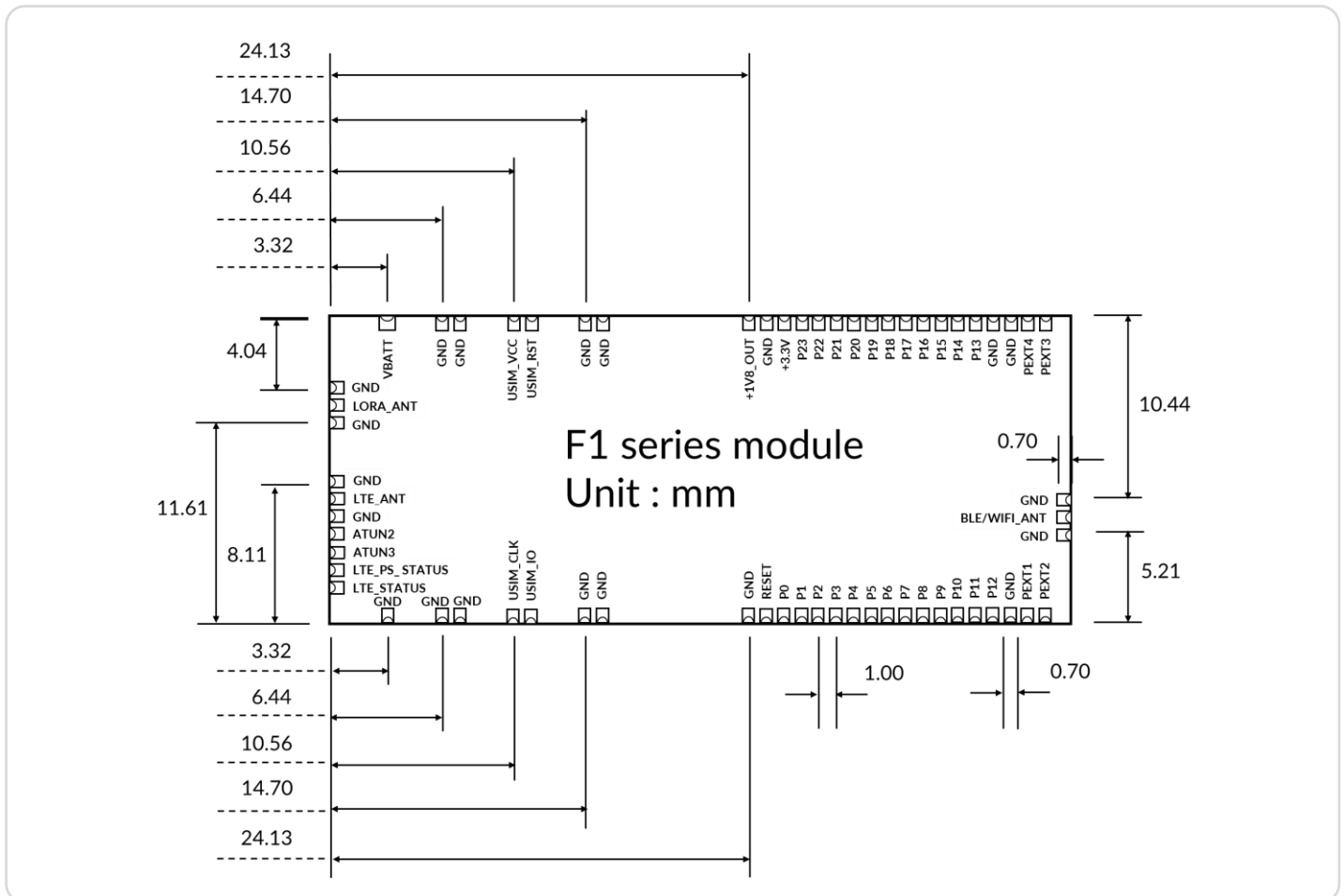

Figure 2: F1 Smart Module Pin Dimensions, Pin Pitches and Pin Locations (Top View)

R30	P7	GPIO3		Analog I/O or Digital I/O	Analog I/O or Digital I/O to ESP32-S3
R31	P8	GPIO46		Digital I/O	Digital I/O to ESP32-S3
R32	P9	GPIO45		Digital I/O	Digital I/O to ESP32-S3
R33	P10	MTCK		Digital I/O	Digital I/O to ESP32-S3
R34	P11	GPIO11		Analog I/O or Digital I/O	Analog I/O or Digital I/O to ESP32-S3
R35	P12	GPIO21		Analog I/O or Digital I/O	Analog I/O or Digital I/O to ESP32-S3
R36	GND			Power	Ground signal
R37	PEXT1	GPIO1		Analog I/O or Digital I/O	Analog I/O or Digital I/O to ESP32-S3
R38	PEXT2	GPIO12		Analog I/O or Digital I/O	Analog I/O or Digital I/O to ESP32-S3
M39	GND			Power	Ground signal
L39	BLE/WIFI_ANT			RF I/O	RF interface to ESP32-S3 for BLE and/or Wi-Fi interface
K39	GND			Power	Ground signal
A38	PEXT4	GPIO14		Analog I/O or Digital I/O	Analog I/O or Digital I/O to ESP32-S3
A37	PEXT3	GPIO13		Analog I/O or Digital I/O	Analog I/O or Digital I/O to ESP32-S3
A36	GND			Power	Ground signal
A35	GND			Power	Ground signal
A34	P13	GPIO20		Analog I/O or Digital I/O	Analog I/O or Digital I/O to ESP32-S3 /USB OTG D+
A33	P14	GPIO19		Analog I/O or Digital I/O	Analog I/O or Digital I/O to ESP32-S3 /USB OTG D-
A32	P15	GPIO38		Digital I/O	Digital I/O to ESP32-S3
A31	P16	GPIO41		Digital I/O	Digital I/O to ESP32-S3
A30	P17	GPIO2		Analog I/O or Digital I/O	Analog I/O or Digital I/O to ESP32-S3
A29	P18	GPIO10		Analog I/O or Digital I/O	Analog I/O or Digital I/O to ESP32-S3
A28	P19	GPIO15		Analog I/O or Digital I/O	Analog I/O or Digital I/O to ESP32-S3
A27	P20	GPIO16		Analog I/O or Digital I/O	Analog I/O or Digital I/O to ESP32-S3
A26	P21	GPIO17		Analog I/O or Digital I/O	Analog I/O or Digital I/O to ESP32-S3
A25	P22	GPIO18		Analog I/O or Digital I/O	Analog I/O or Digital I/O to ESP32-S3
A24	P23	GPIO42		Digital I/O	Digital I/O to ESP32-S3
A23	+3.3V	VDD3P3_CPU VDD3P3_RTC VDD3P3 VDDA		Power	Voltage supply to ESP32-S3 and module main circuit
A22	GND			Power	Ground signal

A21	+1.8V_OUT	VDD_SPI		Power	Voltage supply VDD_SPI to ESP32-S3 for SPI flash and PSRAM
A13	GND			Power	Ground signal
A12	GND			Power	Ground signal
A10	USIM_RST		SIM0_RSTN	Digital I/O	USIM interface I/O to GM02S
A9	USIM_VCC		SIM0_VCC	Power	USIM voltage supply to GM02S
A7	GND			Power	Ground signal
A6	GND			Power	Ground signal
A4	+VBATT		VBAT	Power	Voltage supply to GM02S
E1	GND			Power	Ground signal
F1	LORA_ANT			RF I/O	RF interface to SX1262 for LoRa interface
G1	GND			Power	Ground signal
J1	GND			Power	Ground signal
K1	LTE_ANT		LTE_ANT	RF I/O	RF interface to GM02S for LTE CAT-M1/CAT-NB1/CAT-NB2 interface
L1	GND			Power	Ground signal
M1	ATUN2		GPIO34/ ANT_TUNE0	Analog I/O	ANT_TUNE I/O to GM02S
N1	ATUN3		GPIO35/ ANT_TUNE1	Analog I/O	ANT_TUNE I/O to GM02S
O1	LTE_PS_CTRL		GPIO2/ PS_STATUS	Digital I/O	Power saving status I/O from GM02S
P1	LTE_STATUS		GPIO1/ STATUS_LED	Digital I/O	LTE status I/O from GM02S

c. Recommended PCB Landing Pattern

All pins have a pin width of 0.7mm with the exception of pin VBATT (pin #A4) with pin width 1.0mm.

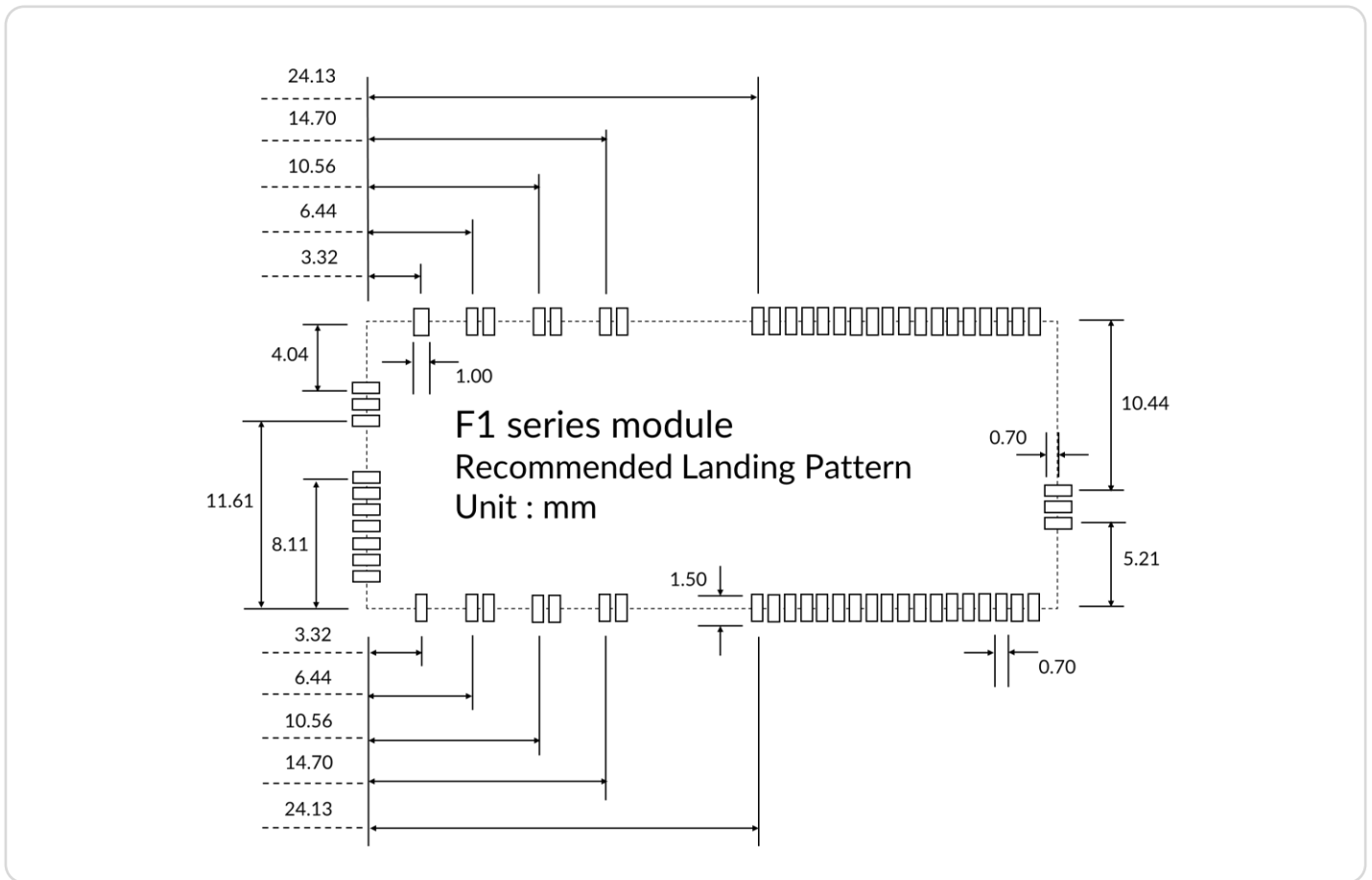

Figure 4: F1 Smart Module Recommended PCB Landing Pattern (Top View)

d. Recommended Basic Circuit

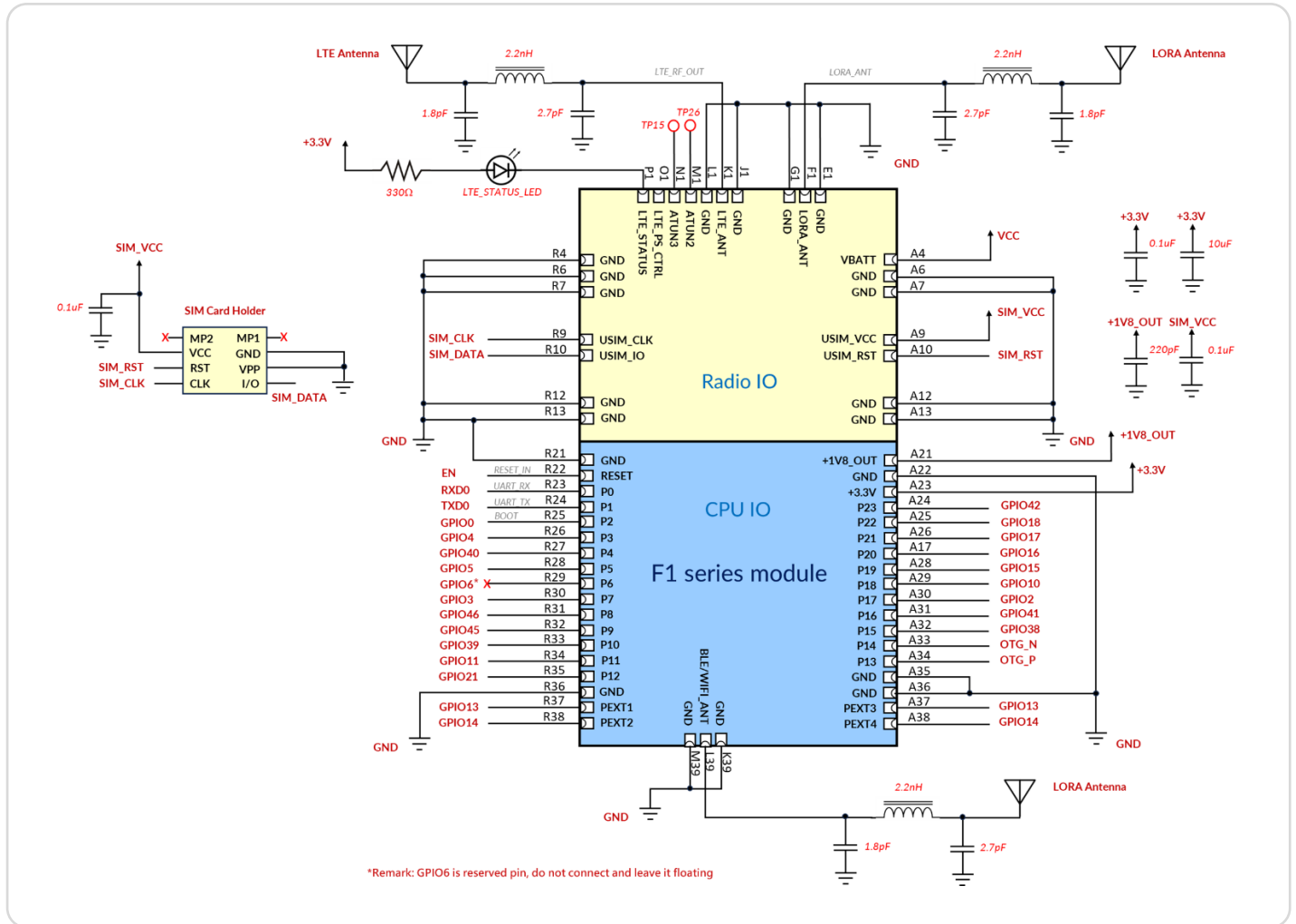

Figure 5: F1 Smart Module Recommended Basic Circuit

e. Recommended Soldering Profile

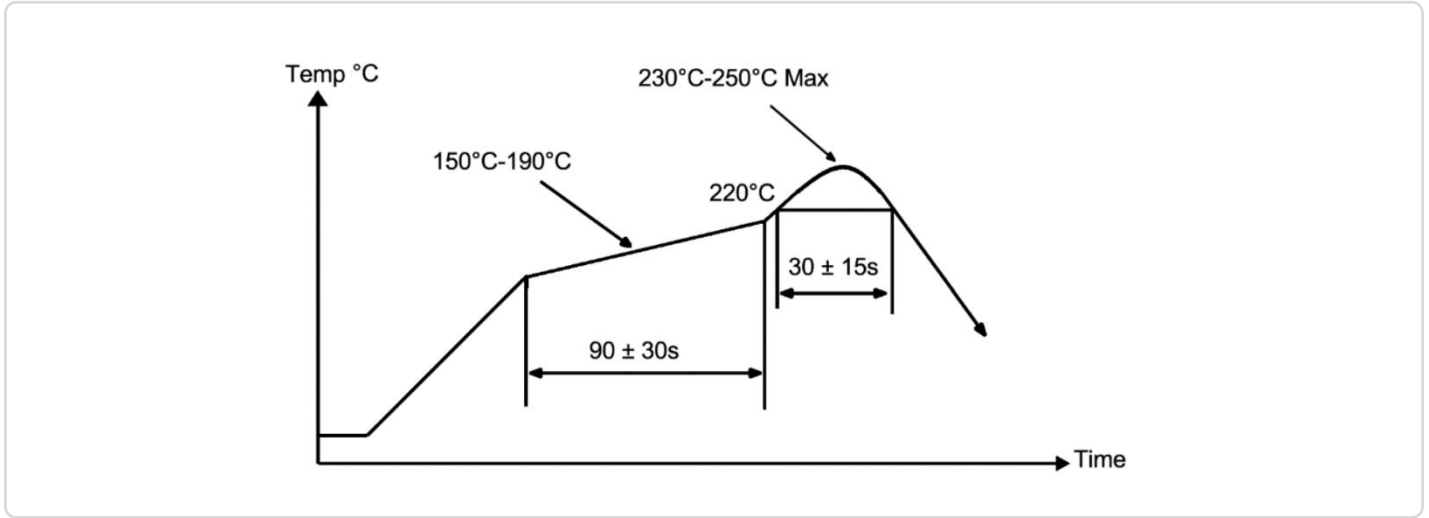

Figure 6: F1 Smart Module Recommended Reflow Soldering Profile

5. MicroPython Application Development on F1

a. Device Programming via UART

- By default, the F1 Smart Module runs an interactive python REPL (Read-Eval-Print-Loop) on UART0 which is connected to P0 (RX) and P1 (TX) running at 115200 baud.
- The Module can be connected via a development board or any USB UART adapter. Code can be run via the REPL and the SG Wireless CtrlR. Visual Studio Code plug-in can also be used to upload code to the board.

b. Module-supported Libraries

Table 9: F1 Smart Module Supported Libraries

Library	Min
Python Standard Libraries*	array, aysncio, binascii, builtins, cmath, collections, errno, gc, gzip, hashlib, heapq, io, json, math, os, platform, random, re, select, socket, ssl, struct, sys, time, zlib, _thread
MicroPython-specific Libraries*	Bluetooth, btree, cryptolib, deflate, framebuf, machine, micropython, neopixel, network, uctypes, esp, esp32
F1 Smart Module-specific Libraries†	lte: Ready-to-use LTE CAT-M1/NB1/NB2 library lora: Ready-to-use LoRa RAW and full stack LoRa WAN device Class A, Class C library ctrl: Ready-to-use Ctrl Cloud Platform client library

* MicroPython documentation library with API function calls (<https://docs.micropython.org/en/latest/library/>).

† SG Wireless F1 Smart Module documentation library with API function calls.

c. MicroPython Capability – REPL (Read-Eval-Print Loop)

The MicroPython-ready F1 Smart Module carries the REPL shell that can execute codes in real-time, as well as enable section-by-section of code execution through a copy-and-paste function, both of which facilitate real-time debugging and instant application code prototyping.

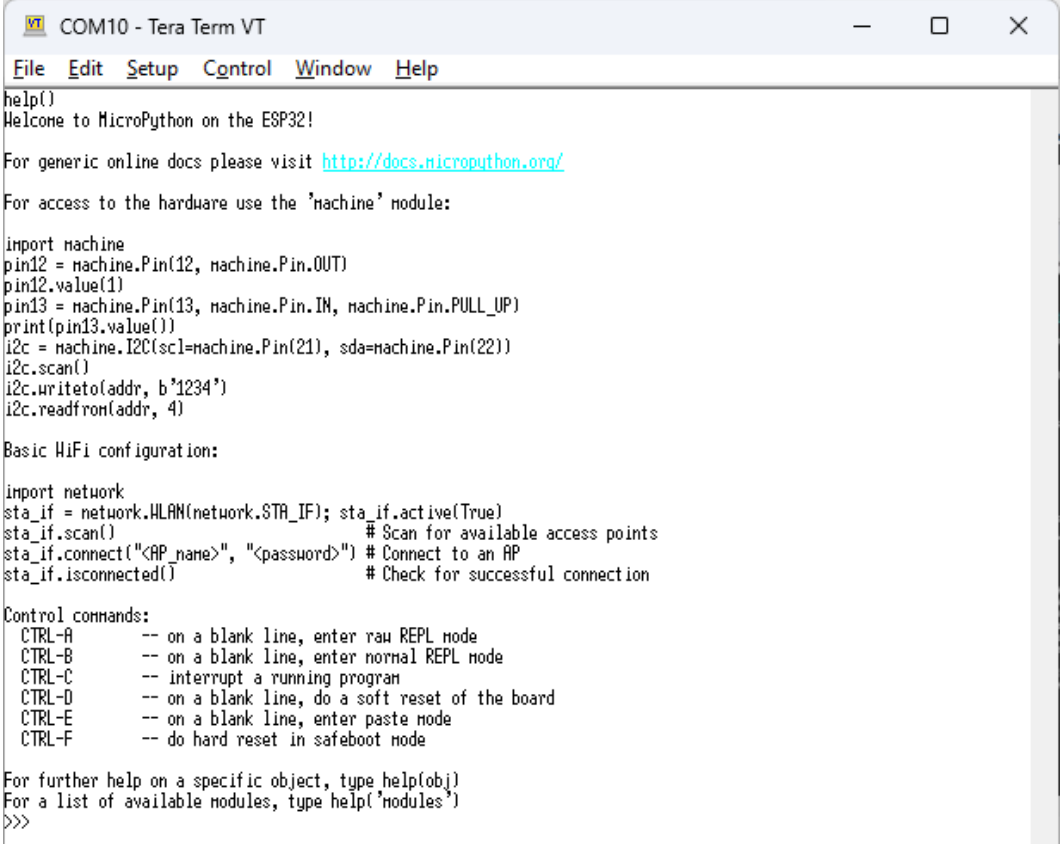

```

COM10 - Tera Term VT
File Edit Setup Control Window Help
help()
Welcome to MicroPython on the ESP32!

For generic online docs please visit http://docs.micropython.org/

For access to the hardware use the 'machine' module:

import machine
pin12 = machine.Pin(12, machine.Pin.OUT)
pin12.value(1)
pin13 = machine.Pin(13, machine.Pin.IN, machine.Pin.PULL_UP)
print(pin13.value())
i2c = machine.I2C(scl=machine.Pin(21), sda=machine.Pin(22))
i2c.scan()
i2c.writeto(addr, b'1234')
i2c.readfrom(addr, 4)

Basic WiFi configuration:

import network
sta_if = network.WLAN(network.STA_IF); sta_if.active(True)
sta_if.scan() # Scan for available access points
sta_if.connect("<AP_name>", "<password>") # Connect to an AP
sta_if.isconnected() # Check for successful connection

Control commands:
CTRL-A -- on a blank line, enter raw REPL mode
CTRL-B -- on a blank line, enter normal REPL mode
CTRL-C -- interrupt a running program
CTRL-D -- on a blank line, do a soft reset of the board
CTRL-E -- on a blank line, enter paste mode
CTRL-F -- do hard reset in safeboot mode

For further help on a specific object, type help(obj)
For a list of available modules, type help('modules')
>>>

```

Figure 7: F1 Smart Module Code Sample in REPL Shell

6. Product Packaging

Modules are packed in tape-and-reel packaging and shipped out in carton boxes.

<p>a. Tape MSL (Moisture sensitivity level): 1</p>	<p>Technical drawing of a carrier tape showing dimensions: 6, 19.2, 24.2, 4.1, 1.6, 56, 4.0, K_o, A_o, B_o, .44.</p>
<p>b. Reel 250pcs per reel</p>	<p>Technical drawing of a reel showing dimensions: 330, 58, 64.</p>
<p>c. Box</p>	<p>Technical drawing of an open carton box showing dimensions: 335, 350, 65.</p>

7. Revision History

Version	Released Date	Description
1.0	Feb 7, 2024	Initial document release
1.1	Mar 6, 2024	Branding revised with updates: Introduction: Operating temperature updated Section 4: Pin number updated (A38 and A37) Section 5b: Link to MicroPython documentation library updated Section 6a: MSL updated

8. Contact

Email: cs@sgwireless.com

Website: <https://sgwireless.com/>

LinkedIn: <https://www.linkedin.com/company/sgwireless/>

Manufacturer Address:

Rm504, 5/F, Sun Fung Industrial Building, 8 Ma Kok Street, Tsuen Wan, New Territories, Hong Kong

Information in this document is provided solely to enable authorized users or licensees of SG Wireless products. Do not make printed or electronic copies of this document, or parts of it, without written authority from SG Wireless.

SG Wireless reserves the right to make changes to products and information herein without further notice. SG Wireless makes no warranty, representation or guarantee regarding the suitability of its products for any particular purpose, nor does SG Wireless assume any liability arising out of the application of any product and specifically disclaims any and all liability, including without limitation consequential or incidental damages. SG Wireless does not convey any license under its patent rights nor the rights of others. SG Wireless products may not be used in life critical equipment, systems or applications where failure of such equipment, system or application would cause bodily injury or death. SG Wireless sells products pursuant to standard Terms and Conditions of Sale which may be found at <https://www.sgwireless.com/page/terms>.

SG Wireless may refer to other SG Wireless documents or third-party products in this document and users are requested to contact SG Wireless or those third parties for appropriate documentation.

SG Wireless™ and the SG and SG Wireless logos are trademarks and service marks of SG Wireless Limited. All other product or service names are the property of their respective owners.

